

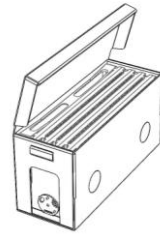

HIVE DOCTOR

M +64 21 526 555
 T +64 6 308 6427
 E info@hivedoctor.com
 W www.hivedoctor.com



HDK060 HIVE DOCTOR SMART NUC +

The most versatile Nuc box available!

- 1-2 minute assembly
- Suitable for overwintering nucs
- Variable ventilation (5 vents max)
- Easily cleaned & sterilised
- Easy removal of bees from box
- 3-6 year life expectancy
- Stackable (60+ Kg)
- Bee Proof
- Flat packed for cheap freight
- Staple for extra strength

(internal feeder or Hive Doctor Feeder system recommended)

HIVE DOCTOR SMART NUC ASSEMBLY INSTRUCTIONS

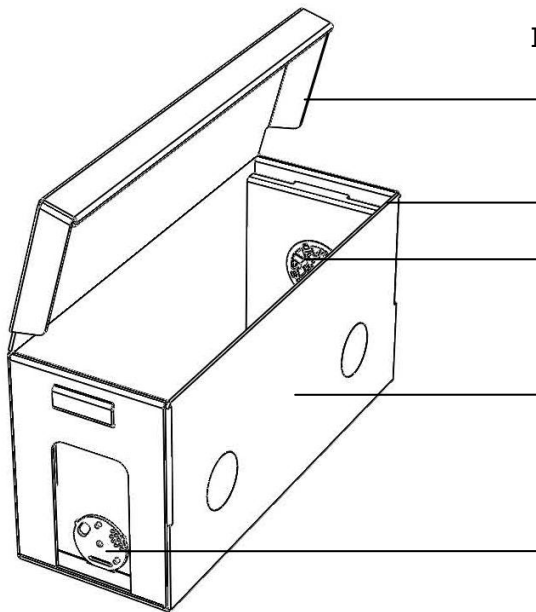

ITEM	PART	DESCRIPTION
1	HDC300	Un- folded Smart Nuc box
2	HDC031	Velcro Dots
3	HDC220	Vent
4	HDC505	Rotating Excluder
4	HDC229	Entrance Disc with fastening pin

DESCRIPTION
Un- folded
Smart Nuc box

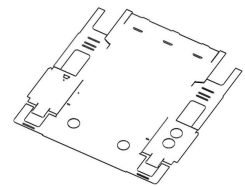

Velcro Dots

Vent



Rotating Excluder

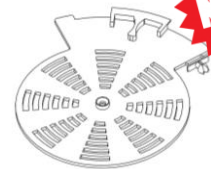

Entrance Disc with fastening pin



ROTATING EXCLUDER - Make Nuc's up quicker and easier than ever!

1. Shake bees off frames or find queen
2. Place Brood & honey frames into the nuc box's
3. Open the excluder on the base of the nuc
4. Place two nucs on top of the parent hive
5. Check in 24 hours for sufficient nurse bees in Nuc's
6. Close the excluders & remove hives
7. Insert queen cell or queen
8. Open nuc box entrances and let the queen mate

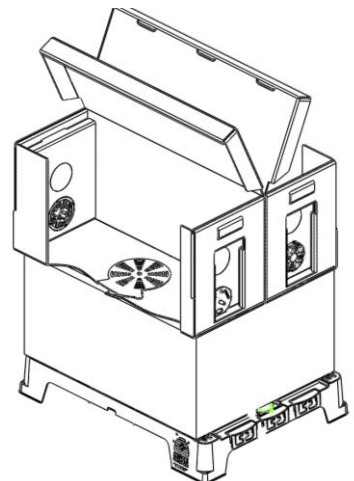

IMPORTANT! To make assembly easier pre bend creased fold lines

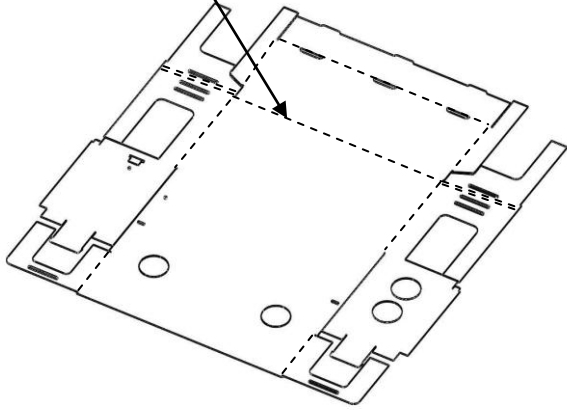

STEP 1 : Fold lid edges

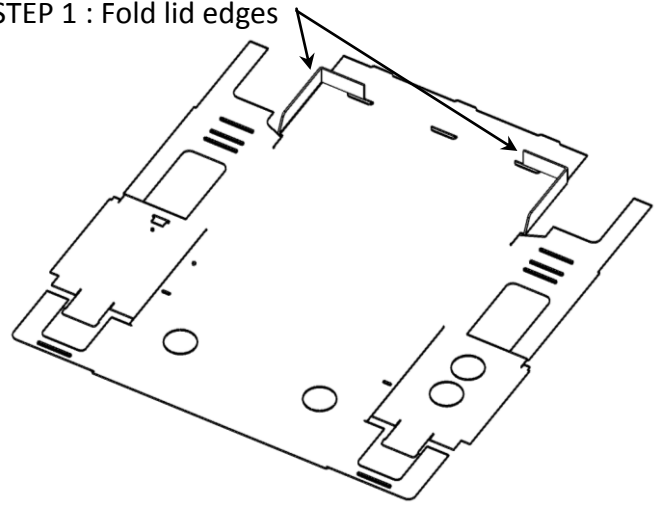

STEP 2 – Fold lid front lip & insert tabs into lid

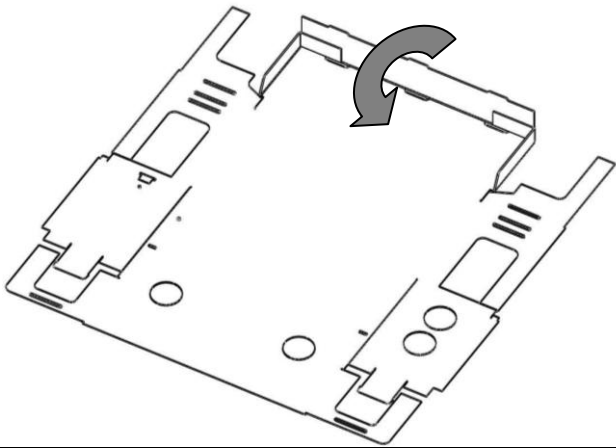

STEP 3- Completed lid !

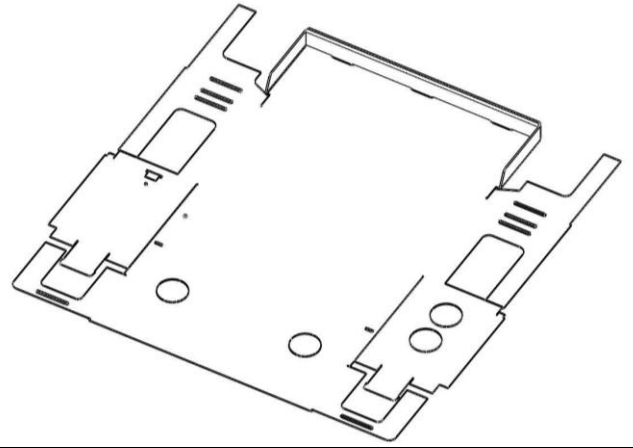

STEP 4- Fold end tabs up

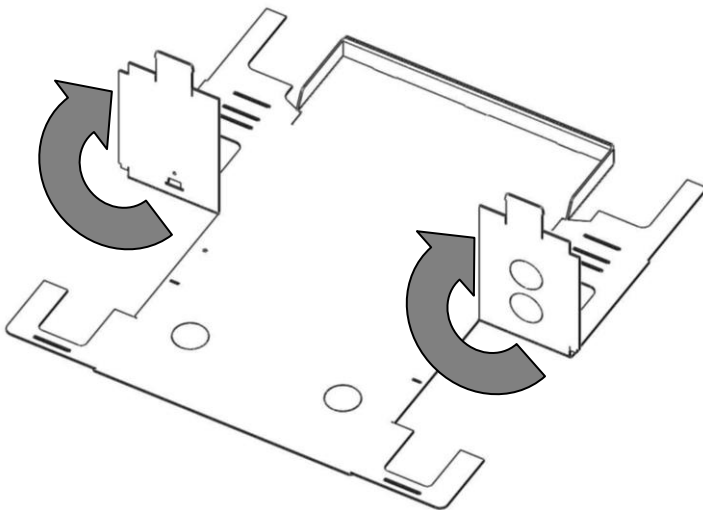

STEP 5- Fold ends into middle of box

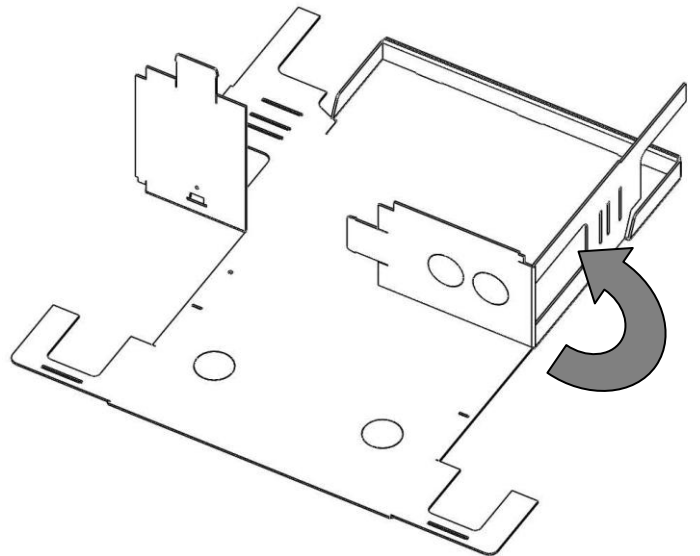

STEP 6- Fold opposite end into middle of box

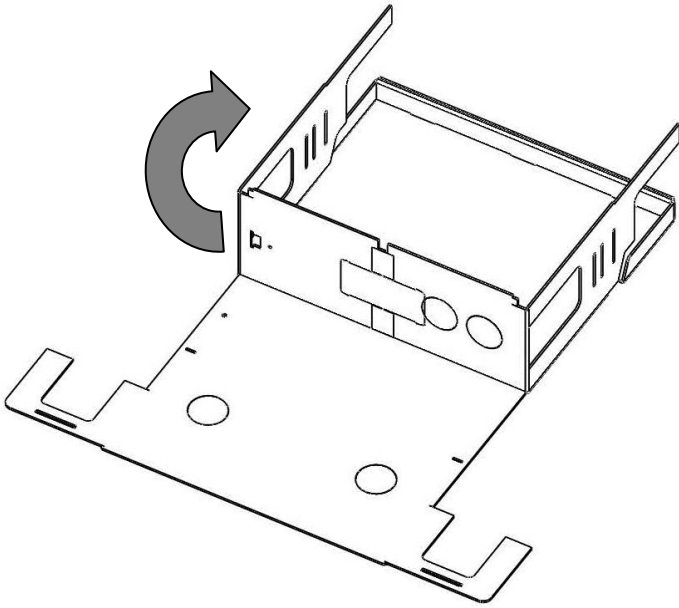

STEP 7- Fold front lock tabs up (on front face of box) (A) then fold box in half to form the floor (B)

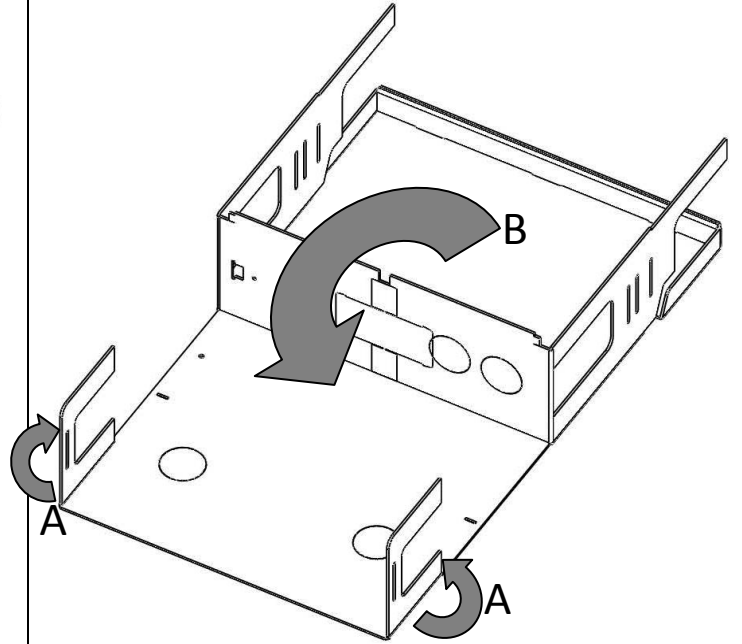

STEP 8-Pre fold edges (A)

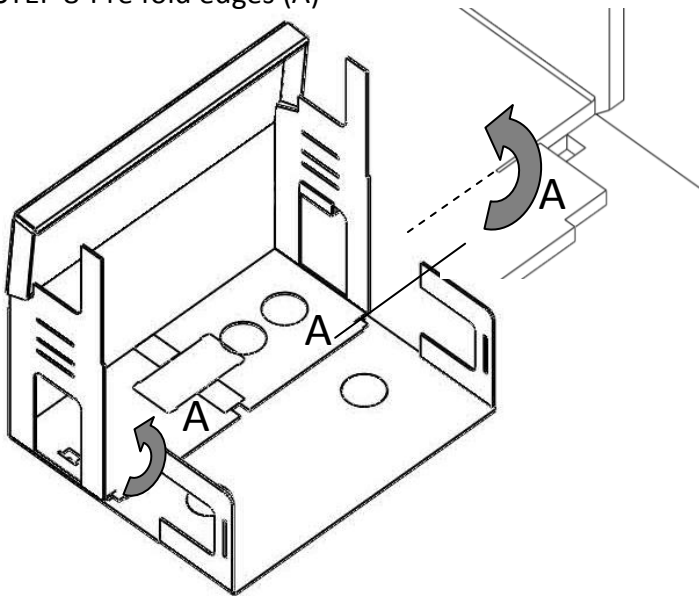

STEP 9- Fold box front (A) then end lock tabs (B) into box. NOTE: Complete one end at a time

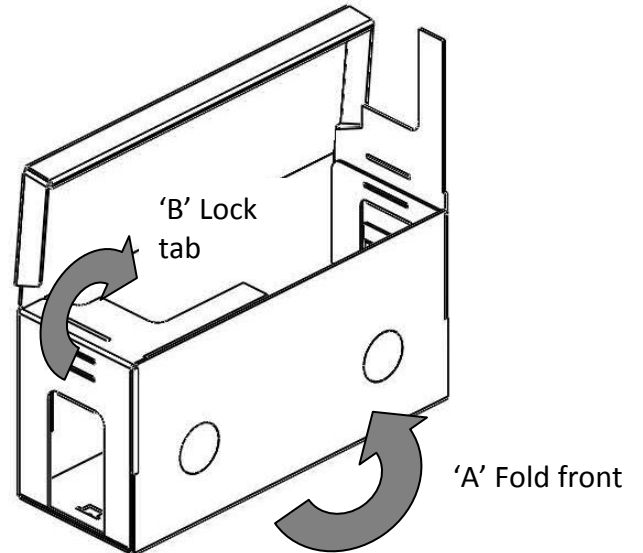

STEP 10- Pre-bend the tabs the frame will sit on

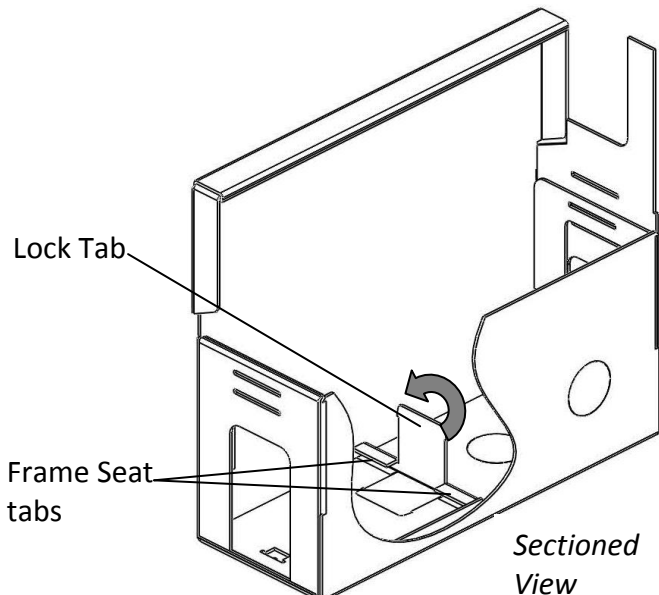

STEP 11- Bend up inside face. Note that the tab (C) inserts into a slot in the base of the box

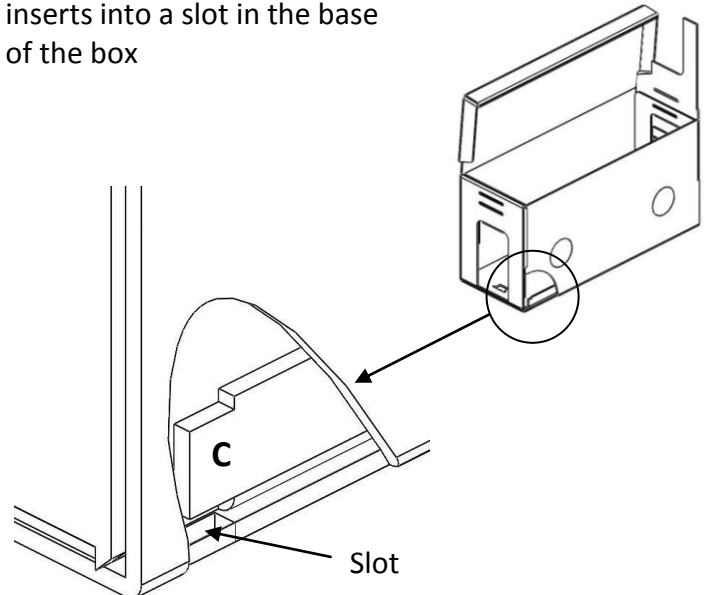

STEP 12- Push on the top of the frame seat area to ensure the tab is pushed through the bottom of the box!

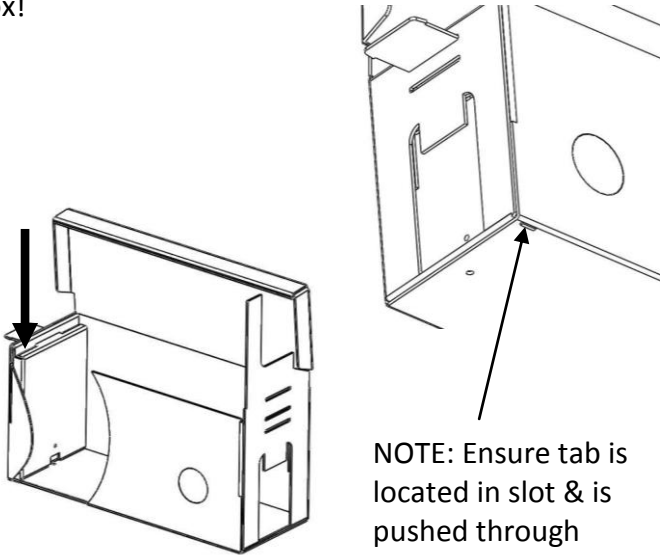

STEP 13 – Insert Lock tab through slots in end of box

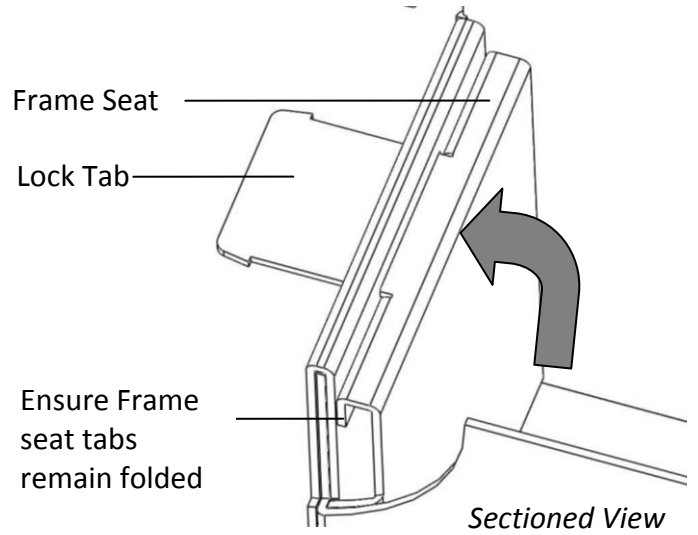

STEP 14 – Thread lock tab as shown (same both ends)

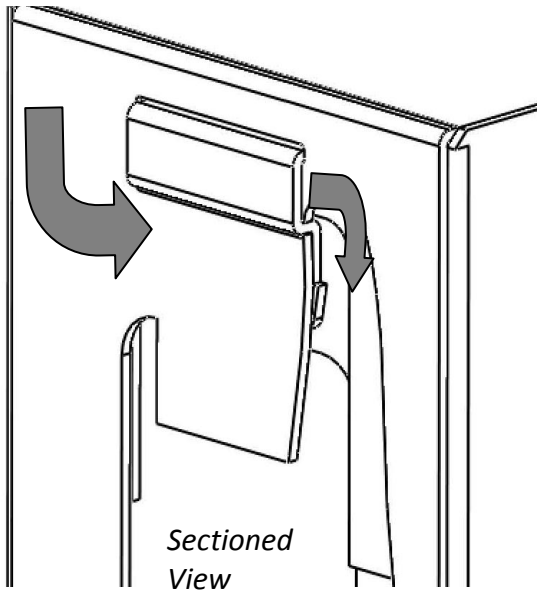

STEP 15 – Roll handle tab into box and push up to lock 'lock tab' in place.

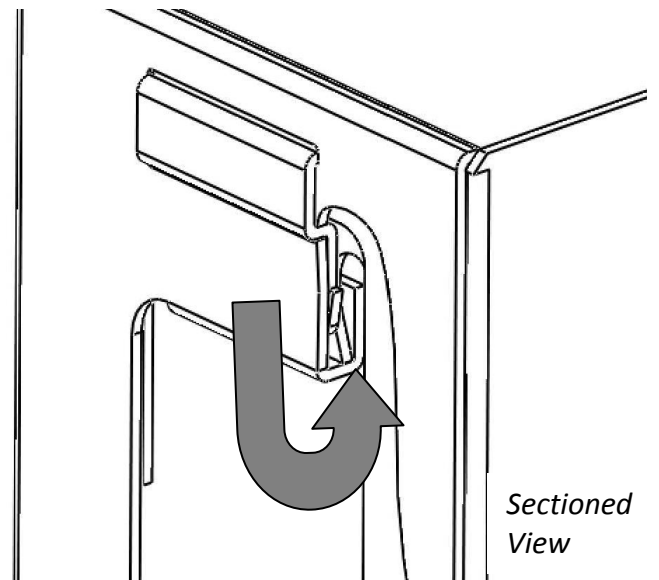

STEP 16 – Copy steps 10 -14 for the opposite end of the box until a basic box is assembled

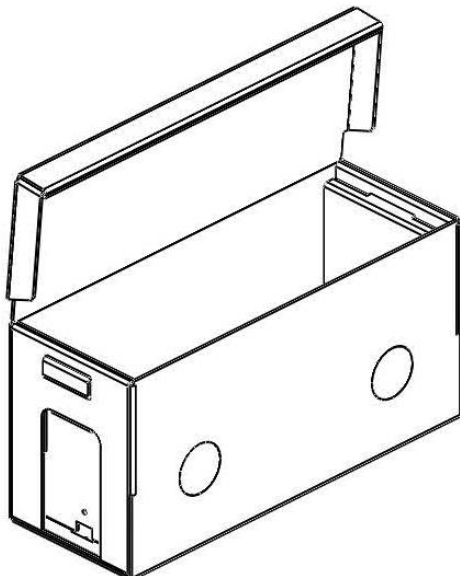

STEP 16 – The further the nuc is transported the more venting is required. If you are overwintering only one will be required. Hot climates will require more!

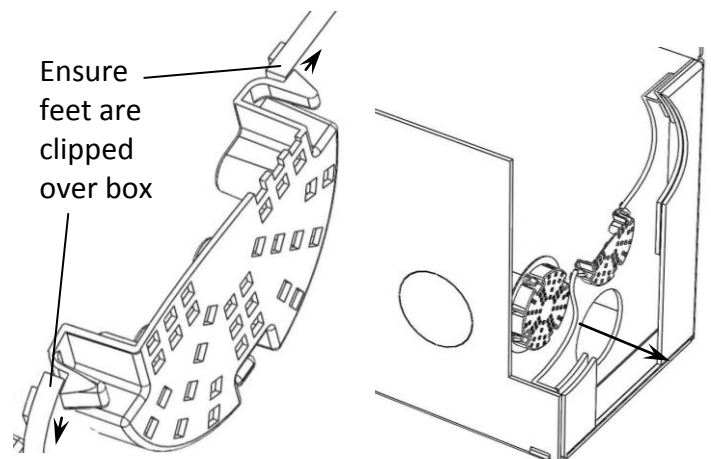

STEP 16 – More Ventilation required ...?

The two side vent Holes can be pushed Out and extra vents inserted.

NOTE: Additional Vents need to be Purchased.

Side Vent hole Push outs

End Vents (2 supplied)

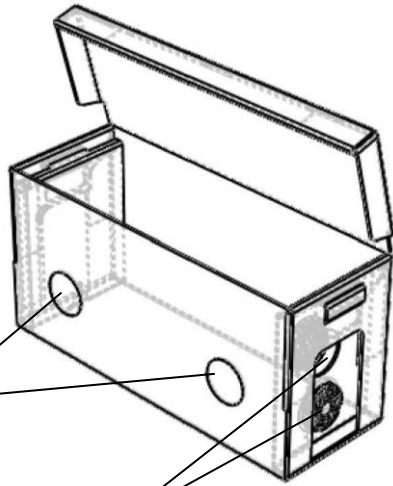

Need Even More Ventilation required....?

A standard 64mm hole saw can be used to cut holes into the box and additional vents can be inserted

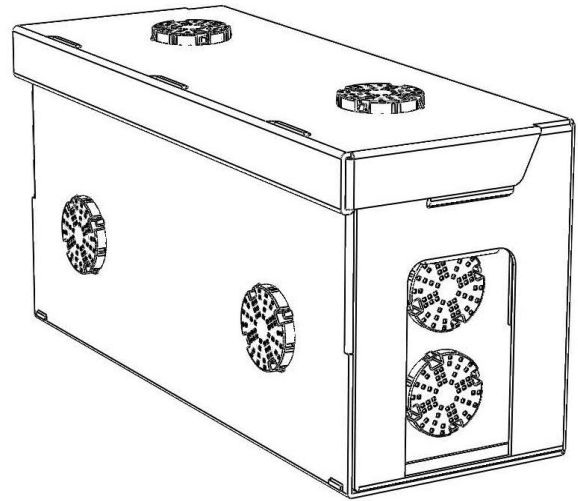

STEP 17 – Assemble Entrance Disc

1. Remove disc fastener from disc
2. Push disc into slot and insert disc fastener through box into disc

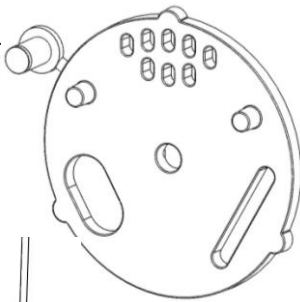
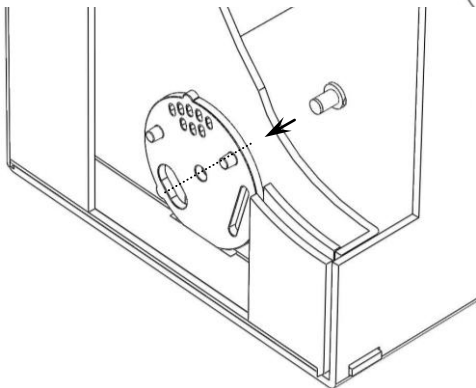

ENTRANCE DISC OPERATION

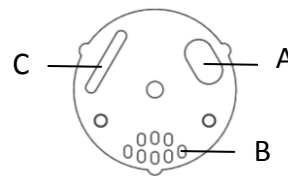

- A – Open Position
- B – Closed/Vented
- C – Bee Capture

NOTE!

Position **C** can be used to capture most field bees during the day if you decide that you need to move the hive during foraging hours. The bees are able to enter the hive but only very small bees will be able to escape.

PUSH VENT / BEE ESCAPE

The push vent can also be modified to turn it into a bee escape! Simply cut as many of the escape gate tabs as you want to make a 1 – 4 exit bee escape.

Escape gate tab

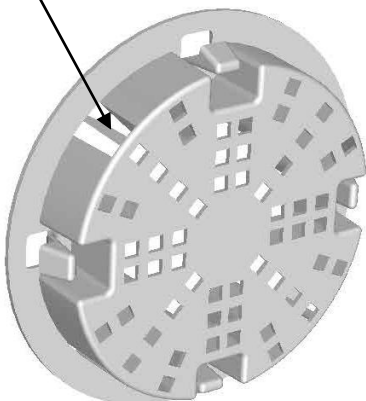

The discs can be inserted in a 3.5mm – 5mm thick board to make escape boards

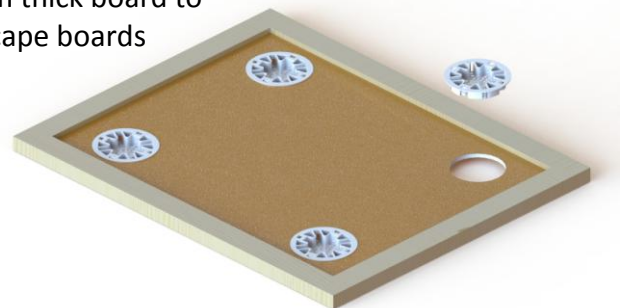

Use a 64mm diameter hole saw to create holes then push escapes into place. No gluing or screwing required!

STEP 18- Velcro Dots can be used to secure the lid

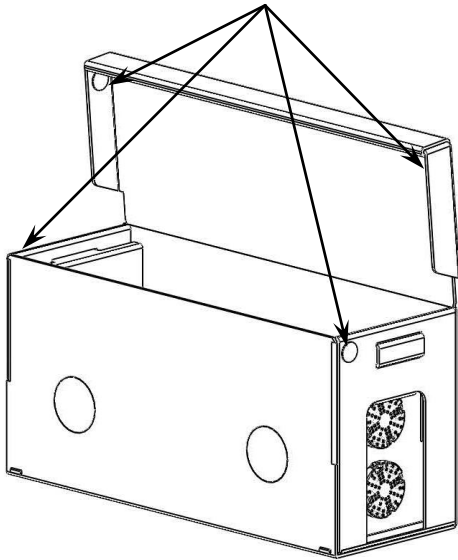

NOTE: Velcro Dots Not Supplied

EXTRA STRENGTH - Increase strength of box by placing a 12mm staple on both sides as shown below.

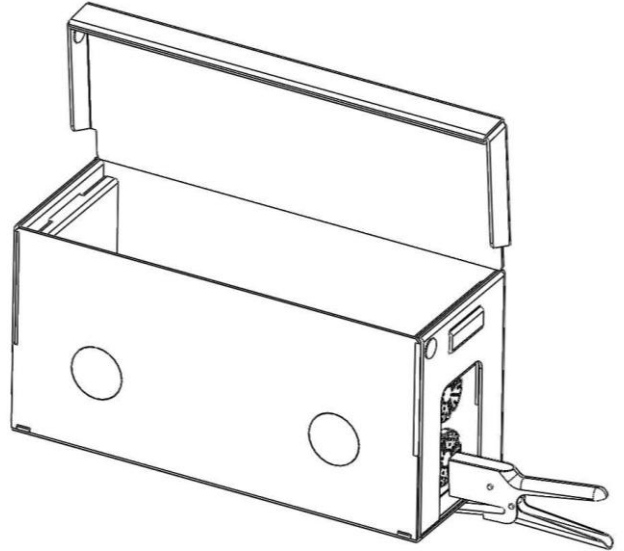

NZ ONLY: Standard Nuc boxes sold in packs of 25 (1m X 1m X 0.10m) Volume= 0.1m³ Weight = 14Kg

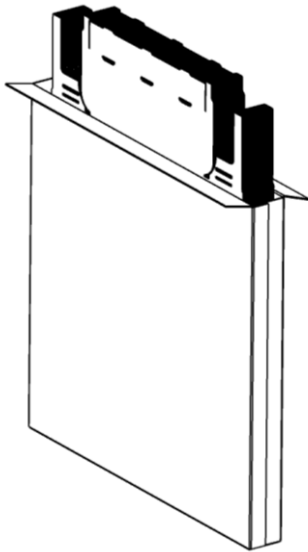

Winter feeding - The nucs will require more frequent visits than standard wooden nucs and the use of an internal feeder or similar is recommended. Additional bee space on the sides has been added to allow the bees to get access to all the frames if only honey frames are relied on.

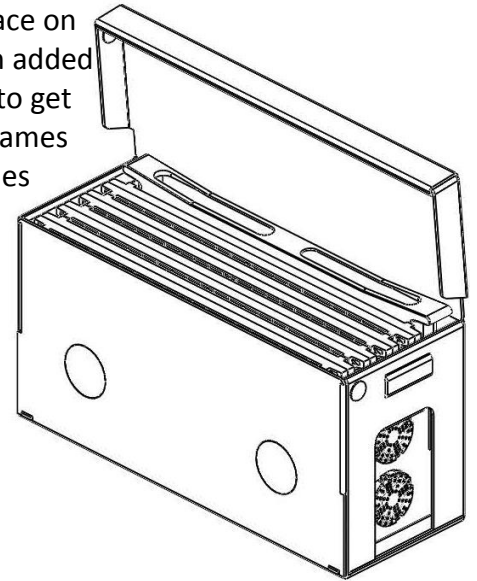

Small Hive Beetle

NOTE: The nuc box has been designed to ensure there is enough frame spacing at the sides of the box for bees to access and deal with any SHB's. Make sure the frames are located evenly with adequate bee space on the sides.

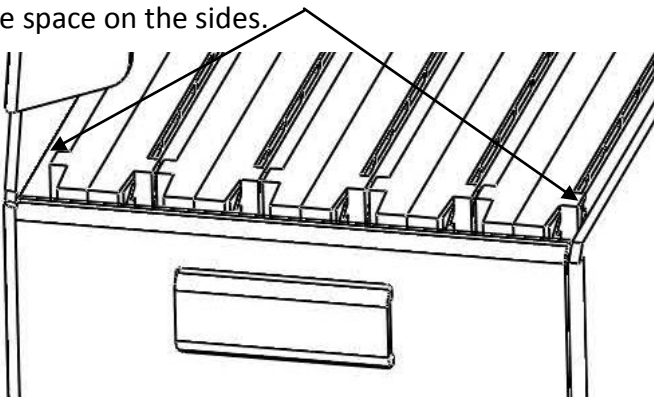

Shipping Nuc's

When shipping it is recommended to use additional vents as the nuc will heat up when stressed. Depending on the number of frames used and the amount of propolis + wax build-up on frames the nuc box may require 2 X 25mm wide 900mm long cardboard inserts to prevent the frames from moving. This will ensure your queen is not squashed!

